

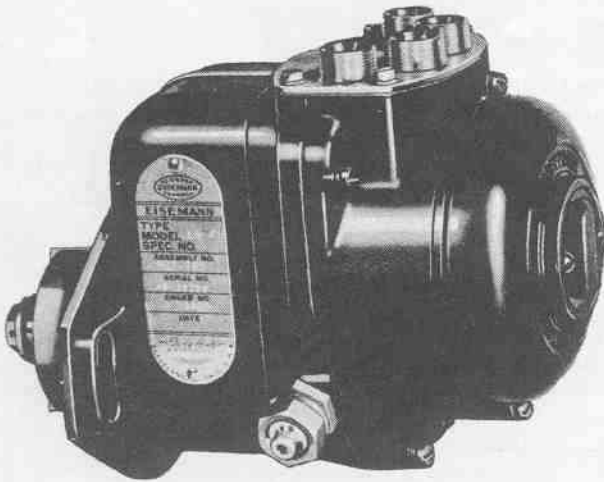

LIGHT-AIRCRAFT SERIES MAGNETOS
SERVICE PARTS CATALOG

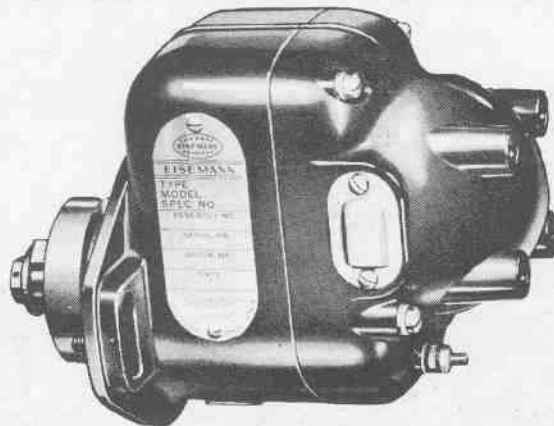

LA-4 MAGNETO



AM-4 MAGNETO

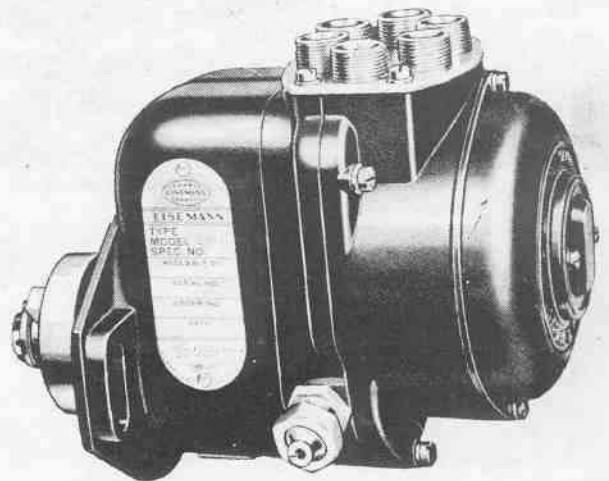

LA-6 MAGNETO

INDEX

Adapter Plate	Page 6
Bearing-Distributor Rotor	Page 4
Bearing-Magnet Rotor	Page 3
Breaker End Plate	Page 5
Cam	Page 3
Coil	Page 4
Condenser	Page 5
Distributor Plate	Page 4
Distributor Rotor	Page 5
End Cover	Page 6
Ground Terminal Ass'y	Page 5
Housing	Page 3
Impulse Starters	Page 7
Parts Group Classification	Page 2
Pinion Gear	Page 3
Rotor-Magnet	Page 3
Top Plate	Page 6

AMERICAN INDUSTRIAL SALES

4365 EAST 10TH LANE HIALEAH, FLORIDA 33012

LIGHT AIRCRAFT "AM-LA" SERIES EISEMANN MAGNETO SERVICE PARTS

Models AM-4, LA-4 and LA-6

This catalog lists all service parts for Light Aircraft "AM-LA" Series Eisemann Magnetos and is designed to give you quick and accurate identification. You must identify the magneto to be serviced by determining the following:

MODEL

ROTATION

SPARK

This can be done by referring to the Eisemann Magneto nameplate and Complete Unit Price List or your Eisemann Magneto Application Chart and Complete Unit Price List. For parts which are not identified by the foregoing, other appropriate notations as to their use are shown in this catalog.

The index on the front cover and the cutaway illustration on this page will give you quick reference to any of the seven major groups of service parts "A" through "G". Parts in each group are illustrated and coded for easy reference to listed part numbers.

Part numbers in each group (except impulse starters) are listed in two columns: The first, "For All Aircraft Magnetos", and the second, "For Specific Aircraft Magnetos". Appropriate identifying notations adjoin parts listed in the second-column.

The Impulse Starter is easily serviced because the part numbers of the flange assembly and cup are stamped on them. Referring to the chart will enable you to assemble complete starters from starter components available and will add elasticity to your stock.

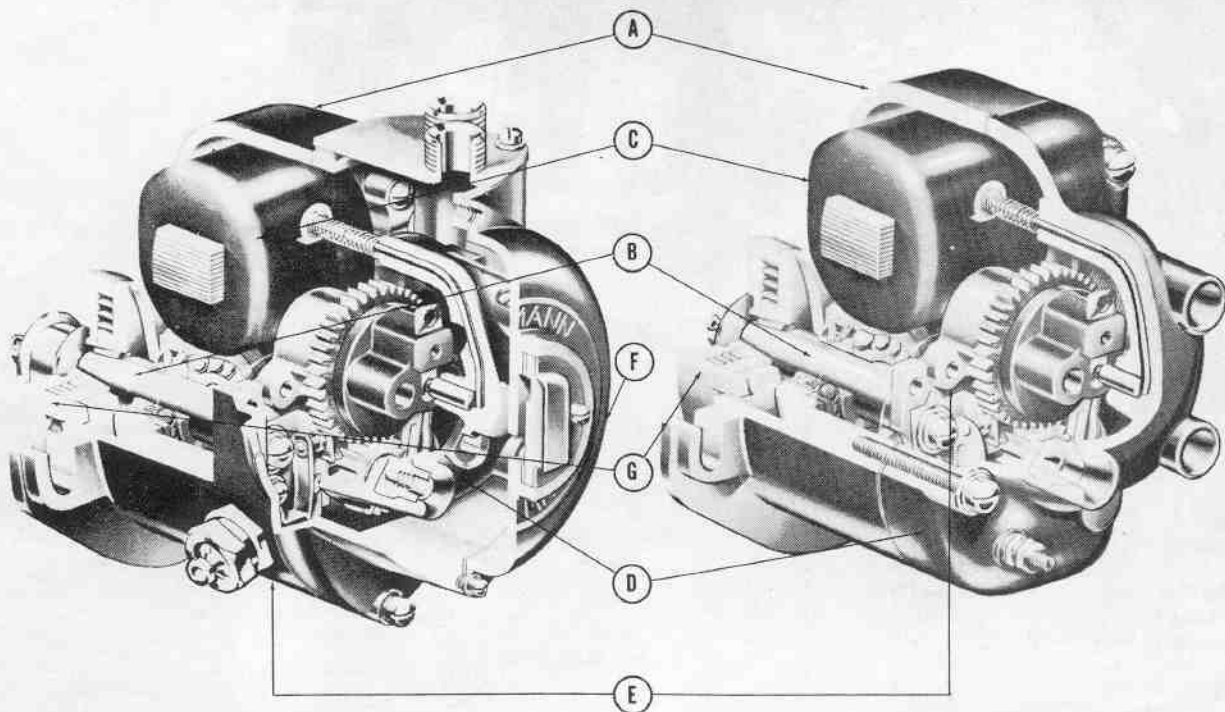

GROUP "A" Page 3	Housing
GROUP "B" Page 3	Magnet Rotor • Pinion Gear • Cam • Ball Bearings
GROUP "C" Page 4	Coil
GROUP "D" Page 4	Distributor Plate • Cable Terminal Clips • Cable Terminal Tubes

GROUP "E" Page 5	Breaker End Plate • Distributor Rotor • Distributor Bearing • Condenser • Breaker • Ground Terminal Ass'y.
GROUP "F" Page 6	Adapter • End Cover • Top Plate
GROUP "G" Page 7	Impulse Starter

GROUP A — HOUSING

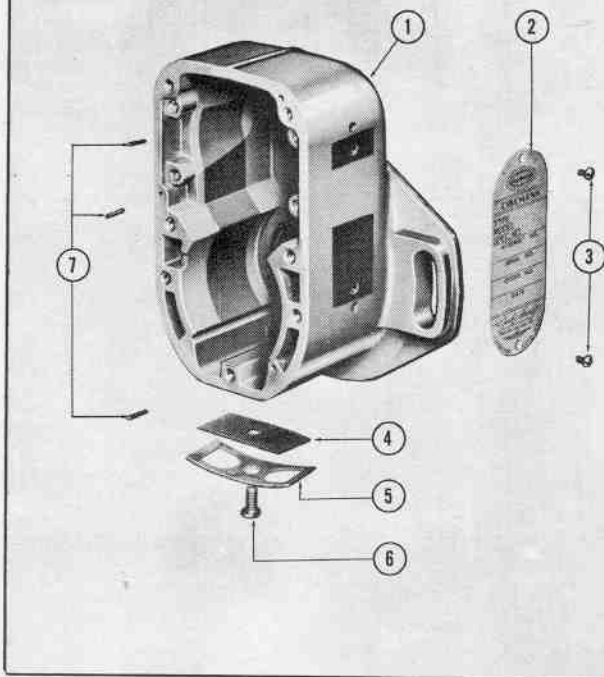

FOR ALL AIRCRAFT MAGNETOS		FOR SPECIFIC AIRCRAFT MAGNETOS	
Code	Description	Part No.	Part No. Application

Code	Description	Part No.	Part No. Application
1.	Housing-Horiz. Fl.	H27-140	
2.	Name Plate	H27-107	
3.	Drive Screw	H26-845	
4.	Ventilator Screen	H24-292	
5.	Ventilator Cover	H20-685	
6.	Screw	H20-558	
7.	Dowel Pin	H22-577	

GROUP B — MAGNET ROTOR

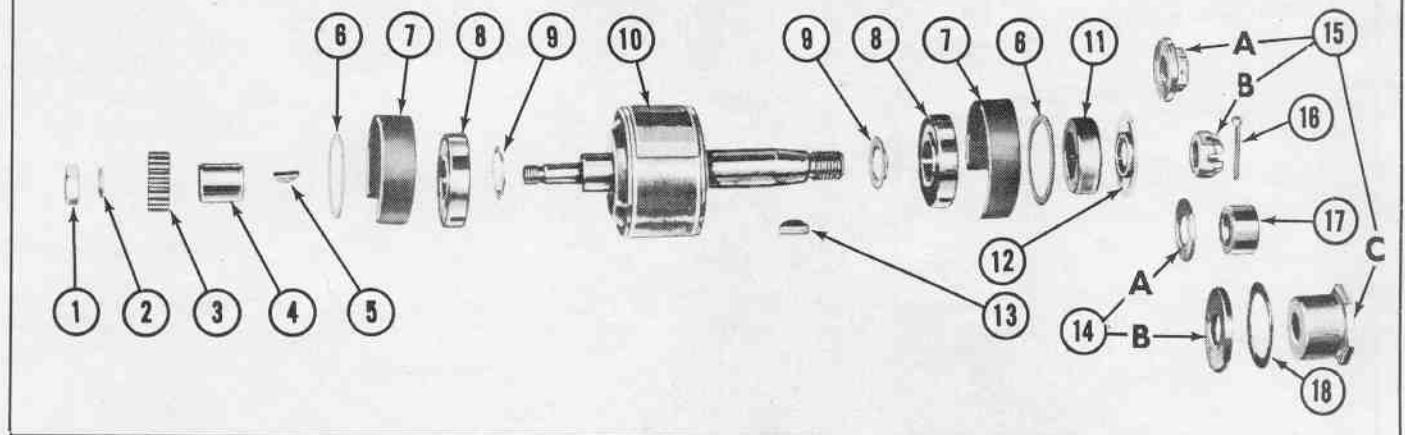

		FOR ALL AIRCRAFT MAGNETOS	FOR SPECIFIC AIRCRAFT MAGNETOS	
Code	Description	Part No.	Part No.	Application
1.	Nut	H23-696		
2.	Lockwasher	H14-199		
3.	a. Pinion Gear	H23-683	AM-4, LA-4	
	b. Pinion Gear	H24-113	LA-5	
4.	a. Cam	H27-635	Refer Spark Symbol F4	
	b. Cam	H23-690	Refer Spark Symbol F3	
5.	Key	H23-724		
6.	a. Shim Washer .008"	H 3-568	*As Required	
	b. Shim Washer .010"	H21-568	*As Required	
	c. Shim Washer .012"	H21-656	*As Required	
	d. Shim Washer .014"	H21-657	*As Required	
7.	a. Shim Strip .008"	H21-241	**As Required	
	b. Shim Strip .010"	H 3-569	**As Required	
	c. Shim Strip .012"	H21-242	**As Required	
	d. Shim Strip .014"	H21-243	**As Required	
	e. Shim Strip .016"	H17-775	**As Required	
8.	Ball Bearing	H 3-507		
9.	a. Shim Washer .004"	H 6-980	***As Required	
	b. Shim Washer .006"	H14-784	***As Required	
	c. Shim Washer .008"	H 6-981	***As Required	

		FOR ALL AIRCRAFT MAGNETOS	FOR SPECIFIC AIRCRAFT MAGNETOS	
Code	Description	Part No.	Part No.	Application
	d. Shim Washer .010"	H14-785		***As Required
	e. Shim Washer .012"	H 6-982		***As Required
	f. Shim Washer .020"	H27-686		***As Required
	g. Shim Washer .022"	H 9-692		***As Required
10.	a. Magnet Rotor		H27-125	Refer Rotor Symbol R5
	b. Magnet Rotor		H27-242	Refer Rotor Symbol R6
	c. Magnet Rotor		H27-730	Refer Rotor Symbol R7
	d. Magnet Rotor		H27-114	Refer Rotor Symbol R8
11.	Oil Seal	H22-981		
12.	Oil Slinger	H24-118		
13.	Key	H 9-179		
14.	a. Thrust Washer	H23-833		Use with Rotor R5
	b. Thrust Washer	H24-906		Use with Rotor R7
15.	a. Nut-Shaft	H23-695		Use with Rotor R5 - R6
	b. Nut-Shaft	H15-266		Use with Rotor R8
	c. Nut-Shaft	H26-032		Use with Rotor R7
16.	a. Cotter Pin	H24-228		Use with Rotor R5 - R6 - R7
	b. Cotter Pin	H27-041		Use with Rotor R8
17.	Bushing	H23-834		Use with Rotor R5
18.	Spacer Washer	H24-904		Use with Rotor R7

* Use Shim Washers to properly locate Outer Ball Race.
 ** Use Shim Strip to obtain press fit on Outer Ball Race.
 *** Use Shim Washers to take up Rotor end play.

GROUP C — COIL

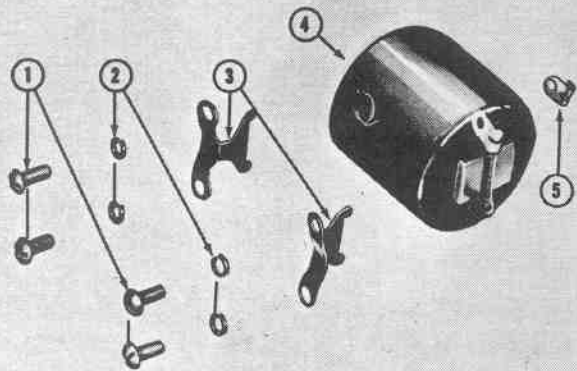

FOR ALL AIRCRAFT MAGNETOS **FOR SPECIFIC AIRCRAFT MAGNETOS**

Code	Description	Part No.	Part No.	Application
1.	Screw	H21-492		
2.	Lockwasher	H24-227		
3.	Coil Clamp	H26-835		
4.	Coil	H27-958		
5.	Terminal Clip	H22-214		

GROUP D — DISTRIBUTOR PLATE

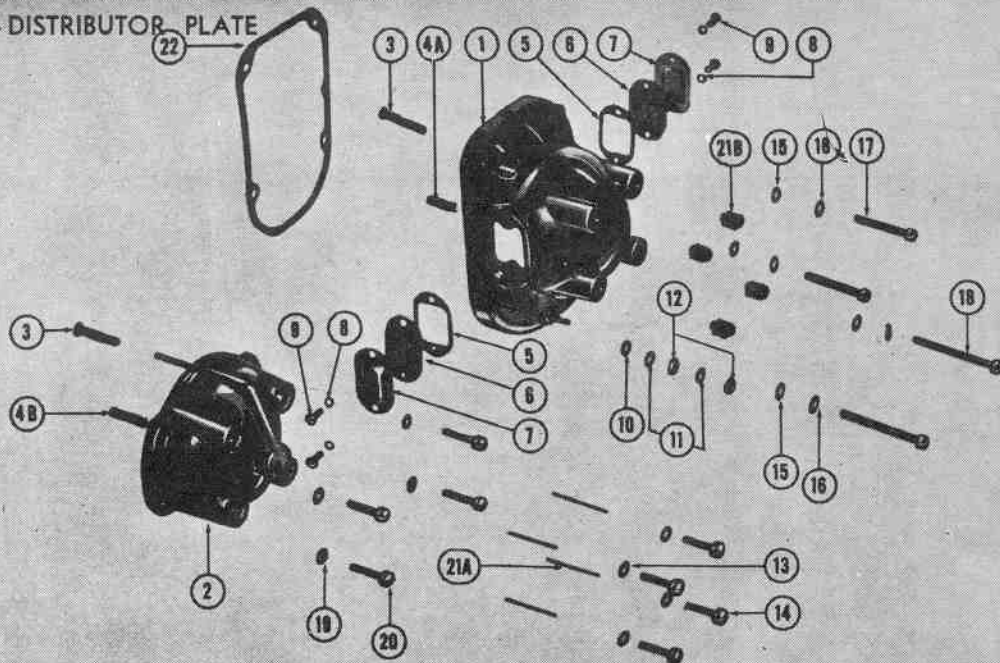

FOR ALL AIRCRAFT MAGNETOS **FOR SPECIFIC AIRCRAFT MAGNETOS**

FOR ALL AIRCRAFT MAGNETOS **FOR SPECIFIC AIRCRAFT MAGNETOS**

Code	Description	Part No.	Part No.	Application
1.	Distributor Plate	H24-923		AM-4
2. a.	Distributor Plate	H27-528		LA-4
2. b.	Distributor Plate	H27-530		LA-6
3.	Contact Spring	*H26-855		
4. a.	Carbon Brush - Cen.	*H 9-922		AM
4. b.	Carbon Brush - Cen.	*H27-136		LA
5.	Ventilator Gasket	*H24-909		AM
6.	Ventilator Screen	*H24-910		AM
7.	Ventilator Hood	*H23-142		AM
8.	Lockwasher	*H22-615		AM
9.	Screw	*H15-123		AM
10.	Washer	*H17-186		AM

Code	Description	Part No.	Part No.	Application
11.	Lockwasher		*H 9-407	AM
12.	Nut		*H26-986	AM
13.	Lockwasher		H 6-767	LA
14.	Screw		H14-718	LA
15.	Washer		H 9-980	AM
16.	Lockwasher		H 6-767	AM
17.	Screw		H21-082	AM
18.	Screw		H21-033	AM
19.	Washer		H18-613	LA
20.	Sem Screw		H29-060	LA
21. a.	Cable Term.-Tube		H26-748	LA
21. b.	Cable Term.-Clip		H21-961	AM
22.	Gasket		H23-691	AM

*These items are furnished with each Distributor Plate and are also sold separately.

GROUP E—BREAKER END PLATE

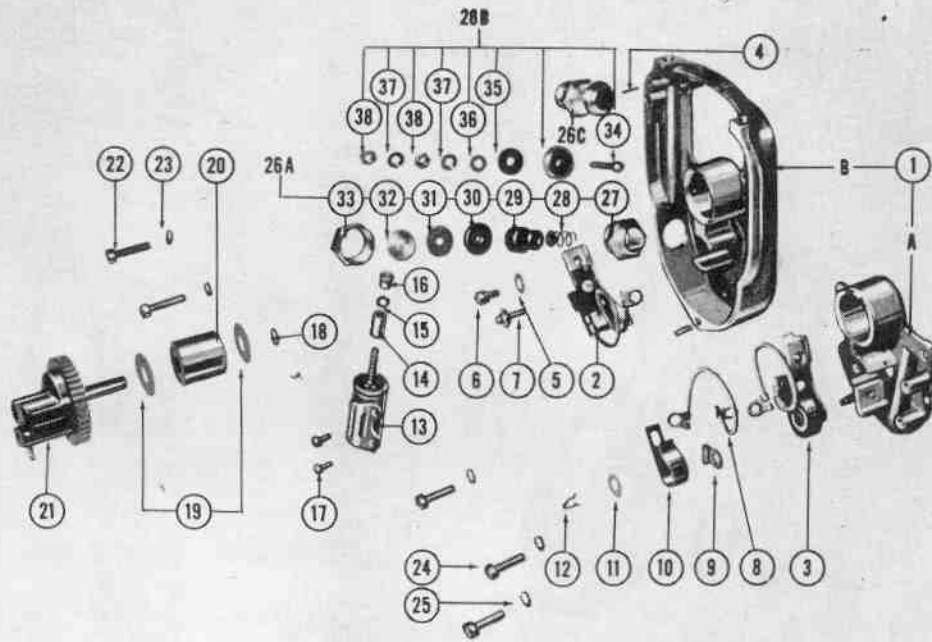

Code	Description	FOR ALL AIRCRAFT MAGNETOS		FOR SPECIFIC AIRCRAFT MAGNETOS	
		Part No.	Part No.	Application	
1. a.	Breaker End Plate		H27-462	AM	
b.	Breaker End Plate		H27-156	LA	
2.	Breaker-Platinum		H27-149	LA	
3. a.	Breaker-Platinum		H24-880	AM	
b.	Breaker-Tungsten		H24-104	Spec. AM Install. H24-631	
4.	Dowel Pin		H22-577	LA	
5.	Washer	H22-654			
6.	Sem Screw	H29-057			
7.	Eccentric Stud		H26-934	LA	
8.	Condenser Lead		H24-229	AM	
9.	Condenser Lead Clamp		H24-968	AM	
10.	Breaker Lever Spring		H23-510	AM	
11. a.	Shim Washer .006"		H20-485	AM *As Required	
b.	Shim Washer .016"		H20-547	AM *As Required	
12.	Lockspring		H20-476	AM	
13.	Condenser	H24-924			
14.	Condenser Post Spacer	H23-697			
15.	Lockwasher	H24-227			
16.	Condenser Post Nut	H22-936			
17.	Sem Screw	H29-056			
18.	Snap Ring	H26-923			
19. a.	Shim Washer .008"		H24-986	**As Required	
b.	Spacer Washer	H22-871			

Code	Description	FOR ALL AIRCRAFT MAGNETOS		FOR SPECIFIC AIRCRAFT MAGNETOS	
		Part No.	Part No.	Application	
20.	Oilite Bearing		H23-727		
21. a.	Distributor Rotor		H24-295	AM-4, LA-4	
b.	Distributor Rotor		H24-105	LA-6	
22.	Screw		H21-528	LA	
23.	Lockwasher		H13-847	LA	
24.	Screw	H21-163			
25.	Lockwasher	H13-847			
26. a.	Ground Terminal-Assy. Shielded		H27-525	LA-Standard	
b.	Ground Terminal-Assy. Unshielded		H24-670	Special for LA Install. H26-317, H27-707	
c.	Ground Terminal		H27-118	Special for LA-6 Install. H27-119	
27.	Ground Adapter		H27-585	Ground Terminal H27-525	
28.	Spring Contact		H26-460	Ground Terminal H27-525	
29.	Insulation Bushing		H27-588	Ground Terminal H27-525	
30.	Neoprene Washer		H27-590	Ground Terminal H27-525	
31.	Aluminum Washer		H27-589	Ground Terminal H27-525	
32.	Ferrule		H27-587	Ground Terminal H27-525	
33.	Lock Nut		H27-586	Ground Terminal H27-525	
34.	Screw		H18-958	Ground Terminal H24-670	
35.	Insulation Washer		H24-662	Ground Terminal H24-670	
36.	Washer		H17-186	Ground Terminal H24-670	
37.	Lockwasher		H 9-407	Ground Terminal H24-670	
38.	Nut		H26-986	Ground Terminal H24-670	

*Use as required for .005" to .012" end play.
 **Use as required for .003" to .008" end play.

GROUP F—ADAPTER, END COVER & TOP PLATE

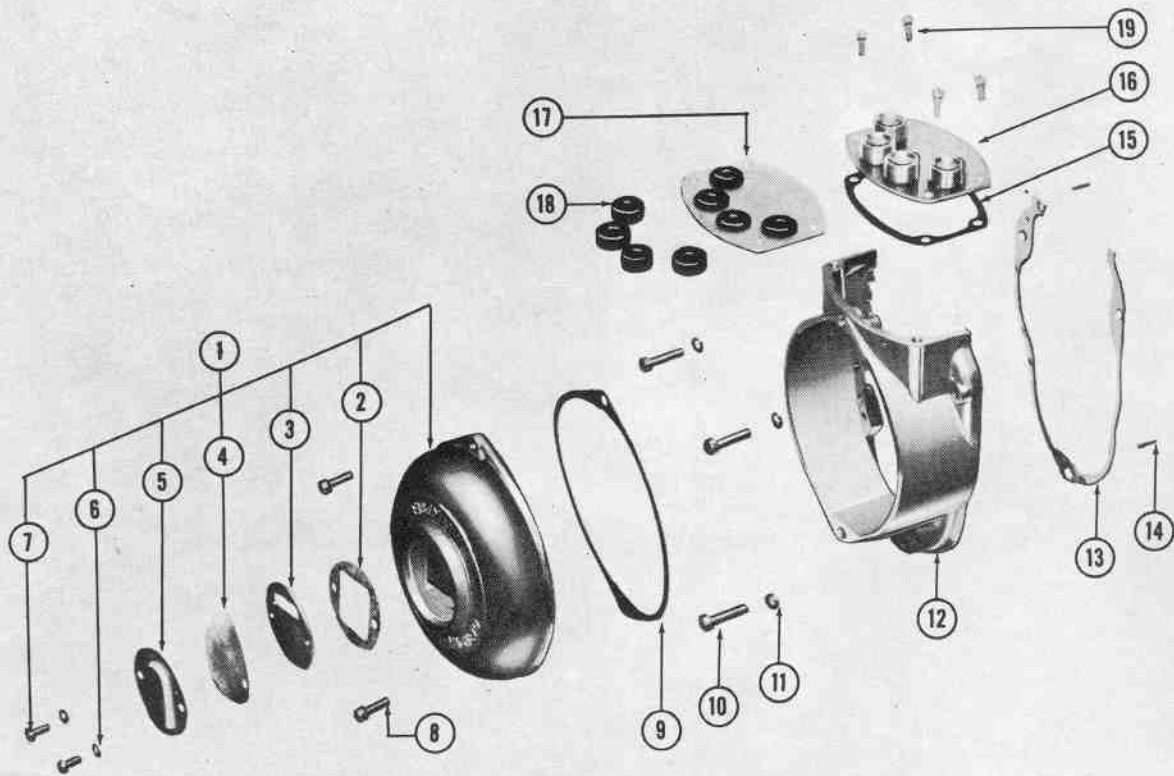

**FOR ALL
AIRCRAFT MAGNETOS**

FOR SPECIFIC AIRCRAFT MAGNETOS

CODE	DESCRIPTION	Part No.	Part No.	Application
1.	End Cover		H26-422	LA
2.	Ventilator Gasket		*H26-991	End Cover
3.	Ventilator Plate		*H26-994	End Cover
4.	Ventilator Screen		*H26-992	End Cover
5.	Ventilator Hood		*H26-993	End Cover
6.	Lockwasher		*H22-615	End Cover
7.	Screw		*H15-123	End Cover
8.	Sem Screw		H29-059	End Cover
9.	Gasket		H26-963	End Cover
10.	Screw		H21-528	Adapter Plate
11.	Lockwasher		H 6-767	Adapter Plate
12.	Adapter Plate		H27-117	LA
13.	Gasket		H26-965	Adapter Plate
14.	Dowel Pin		H22-577	Adapter Plate
15.	Gasket		H26-964	Top Plate
16. a.	Top Plate-Ferrule		H26-428	LA-4 Install. H24-650, H24-671
b.	Top Plate-Ferrule		H27-675	LA-4 Install. H27-630, H27-704, H27-711
c.	Top Plate-Ferrule		H27-674	LA-4 Install. H27-632, H27-676, H27-709
d.	Top Plate-Ferrule		H26-430	LA-6 Install. H27-119
e.	Top Plate-Ferrule		H27-693	LA-6 Install. H27-691, H27-713, H27-725
17. a.	Top Plate-Grommet		H26-076	LA-4 Install. H26-317, H27-707
b.	Top Plate-Grommet		H26-077	LA-6 Install. H24-651, H27-700
18.	Rubber Grommet		H26-847	Top Plate H26-076, H26-077
19.	Sem Screw		H29-059	Top Plate

*These items are furnished with End Cover H26-422 and are also sold separately.

GROUP G — IS-7 IMPULSE STARTERS

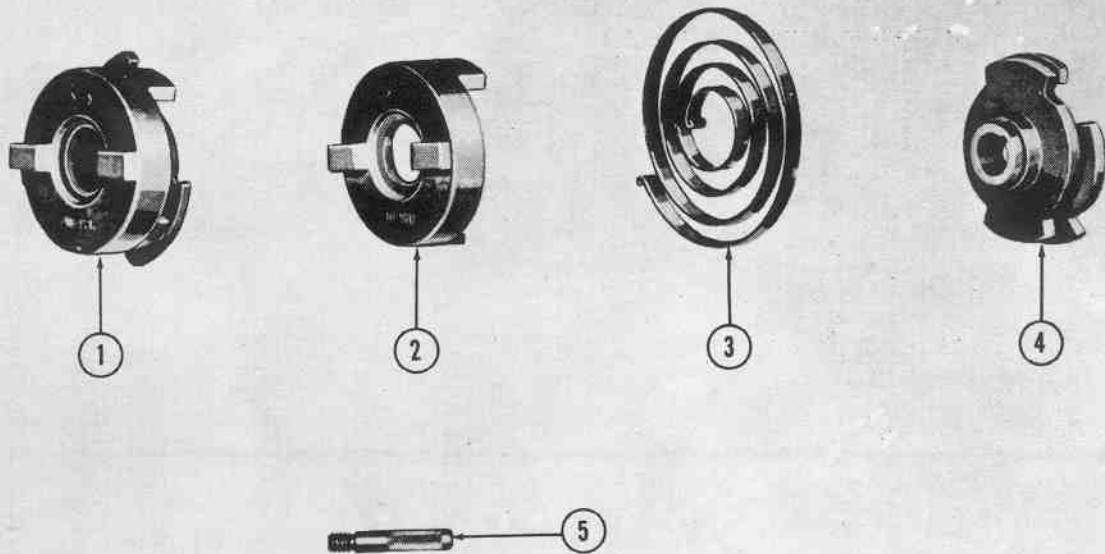

Code	DESCRIPTION	FOR ALL STARTERS		FOR SPECIFIC STARTERS		Application
		Part No.	Part No.	Part No.	Part No.	
1.	Starter					Refer Code 1 Column above
2.	Drive Cup					Refer Code 2 Column above
3.	Starter Spring	H23-816				
4.	Flange					Refer Code 4 Column above
5.	Catch Pin	*H23-810				

*Catch Pin H23-810, if required, must be ordered separately as it is not a component of the Impulse Starter.

Note: For specific application refer to MAGNETO PRICE LIST or APPLICATION CHART

CLOCKWISE					ANTICLOCKWISE				
Lag	Lug	Code 1 Starter	Code 2 Drive Cup	Code 4 Flange	Lag	Lug	Code 1 Starter	Code 2 Drive Cup	Code 4 Flange
25°	30°	H23-753	H26-149	H23-773	25°	30°	H23-763	H23-817	H23-783
25°	30°	H24-673	H26-796	H23-773	40°	45°	H23-766	H23-817	H23-786
25°	30°	H26-163	H26-200	H23-773	25°	30°	H26-173	H26-201	H23-783
35°	40°	H26-795	H26-796	H23-775	40°	45°	H26-176	H26-201	H23-786
					35°	45°	H27-698	H27-699	H23-785
					40°	45°	H27-793	H27-792	H23-786